

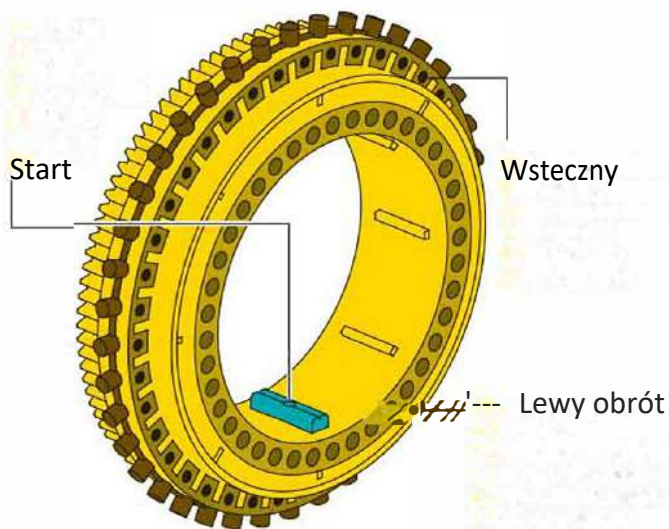

DISQUE DE CODAGE - CODING WHEEL - CODIERRADS CODERINGSSCHIJF - DISCO CODIFICADOR - DISCO DI PROGRAMMAZIONE

PROGRAMOWANIE KOŁA

Lewa strona



Prawa strona

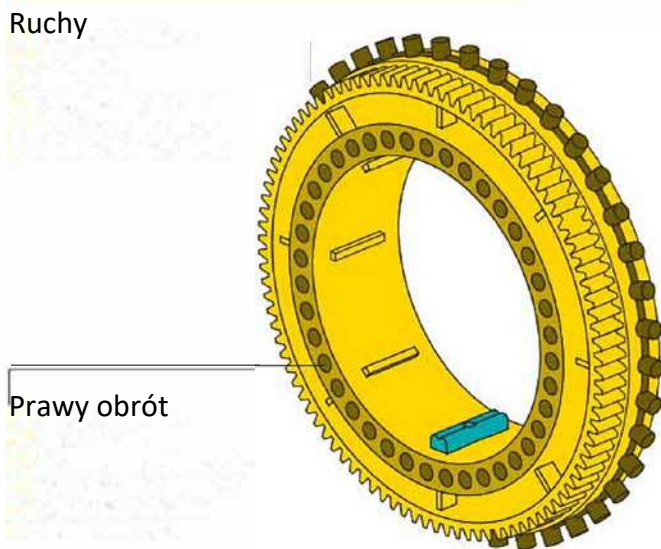

Ruchy

Podnośnik

Wsteczny

Obrót o 90 stopni

Obrót o 45 stopni

1

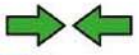

Naciśnij

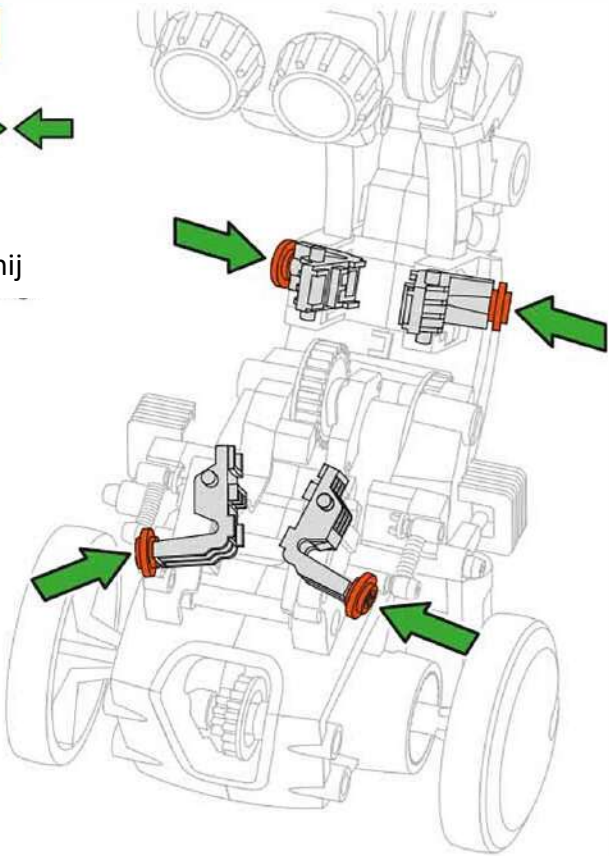

Widok z góry

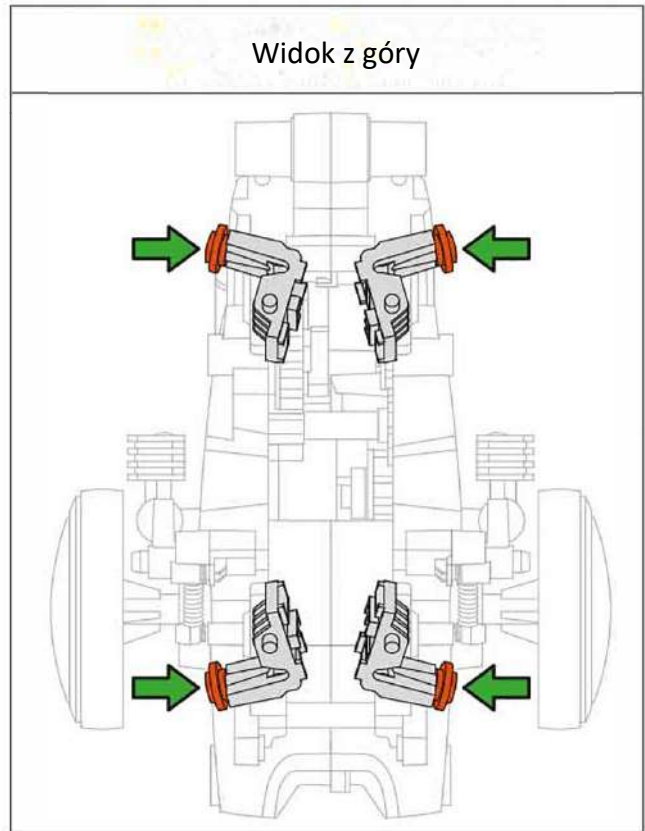

2

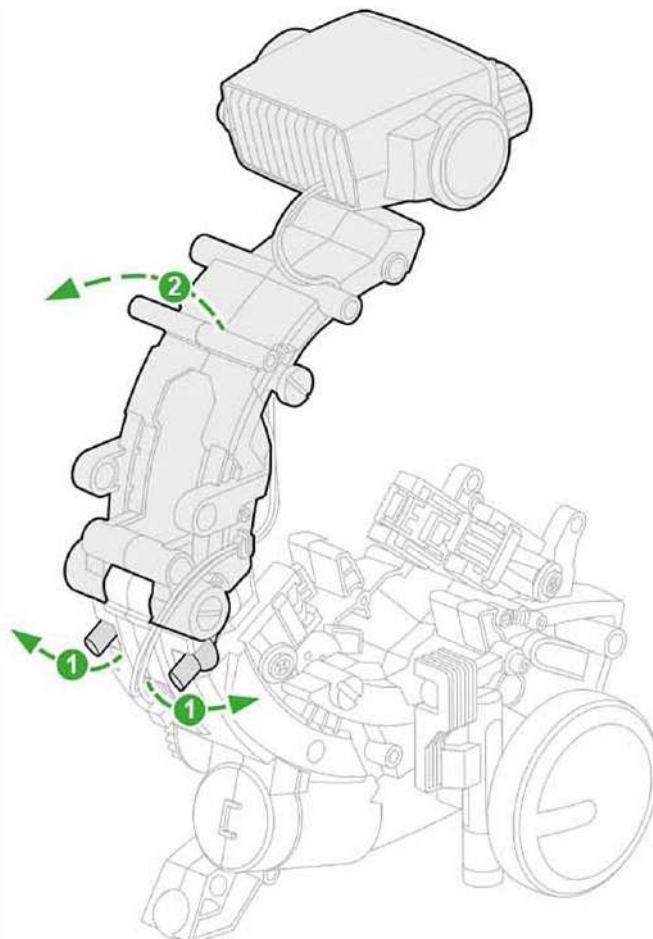

3

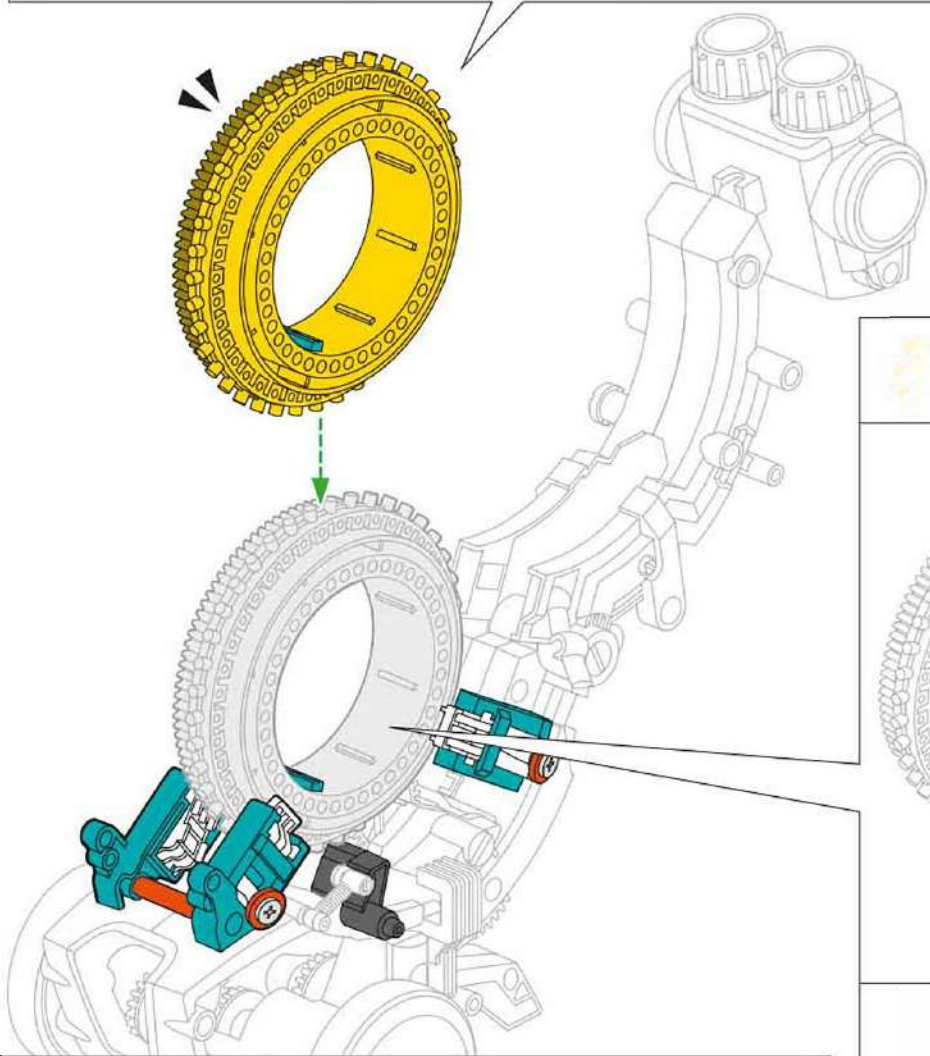
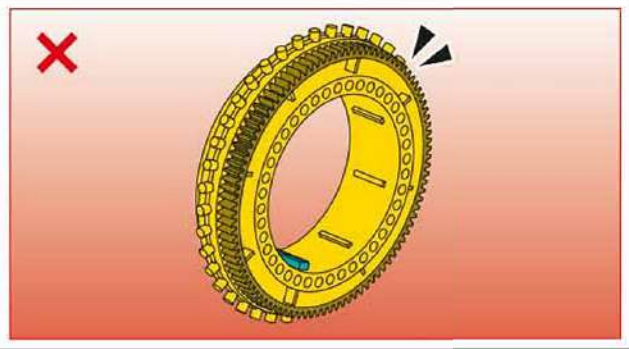
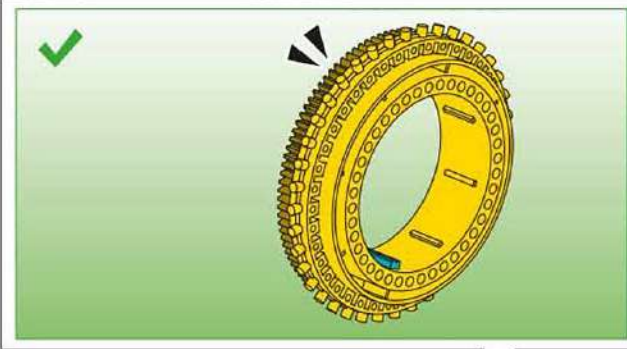

Pozycja wyjściowa

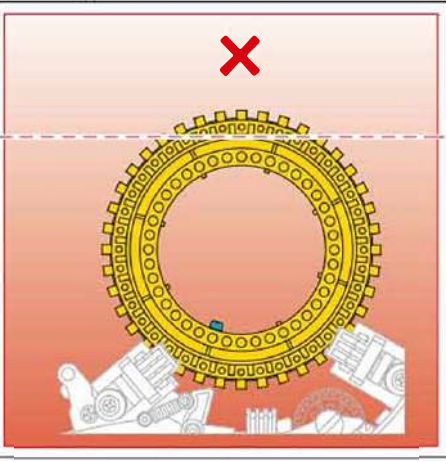
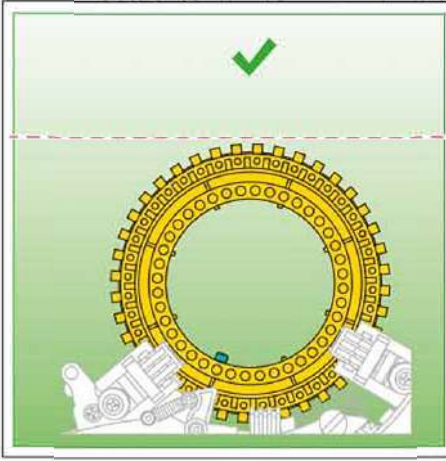
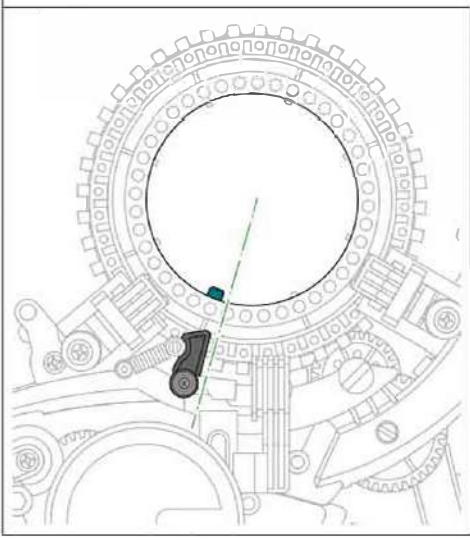
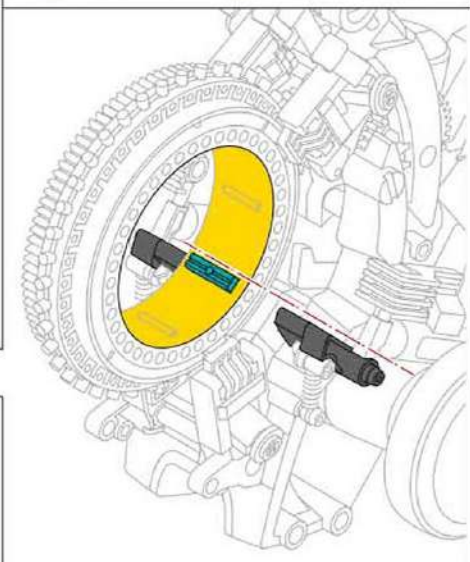

4

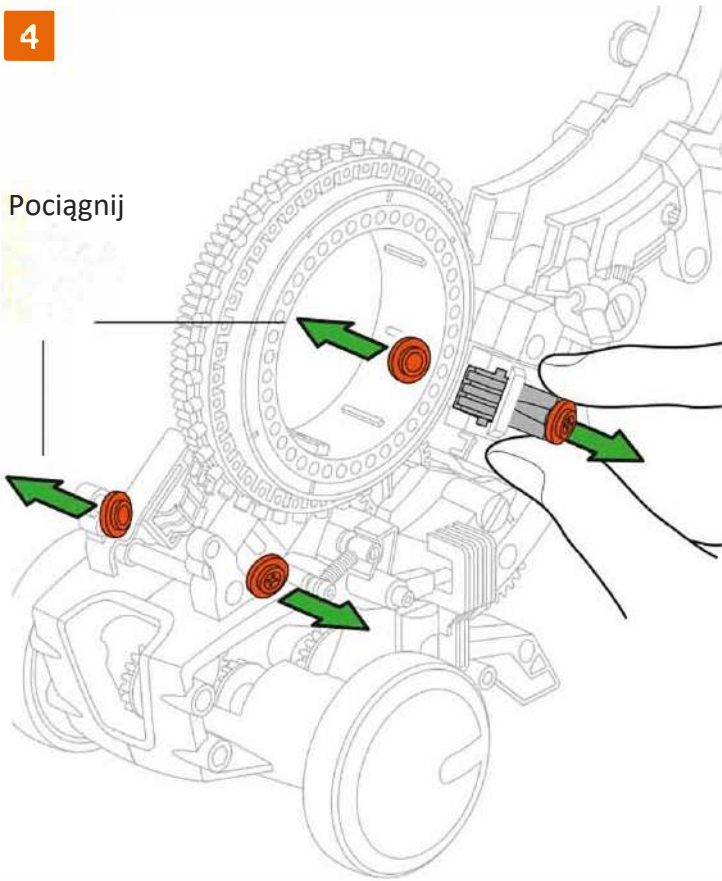

Widok z przodu

Pociąnij

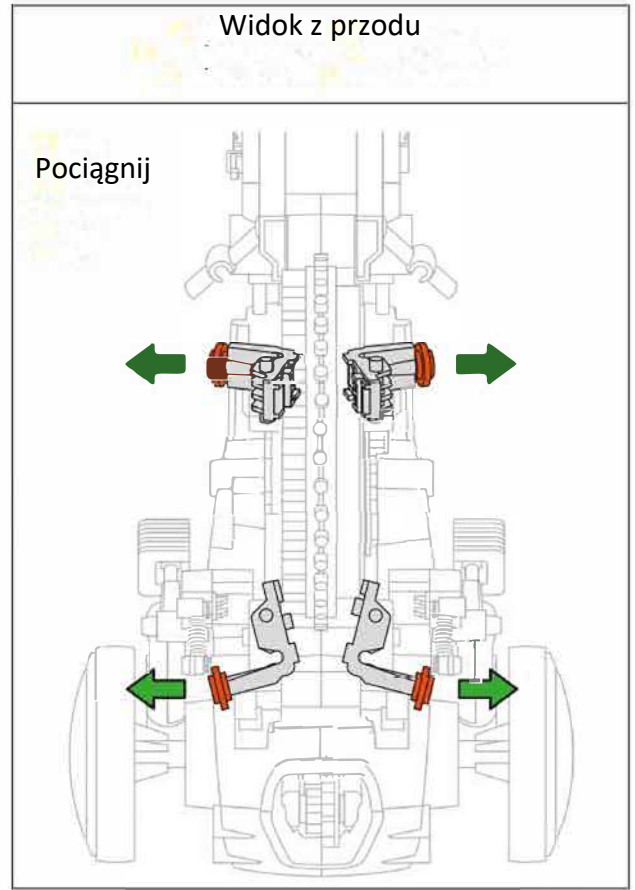

5

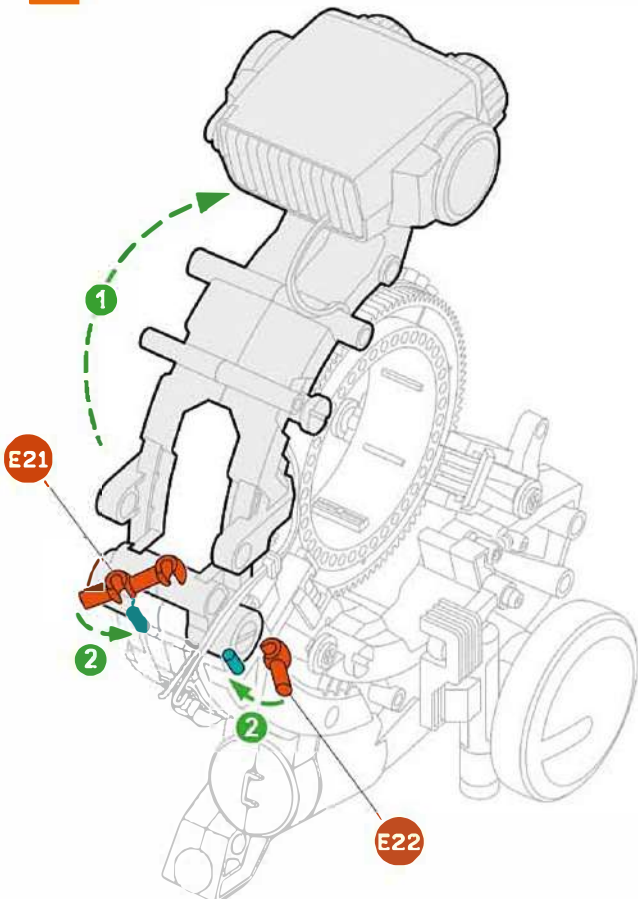

6

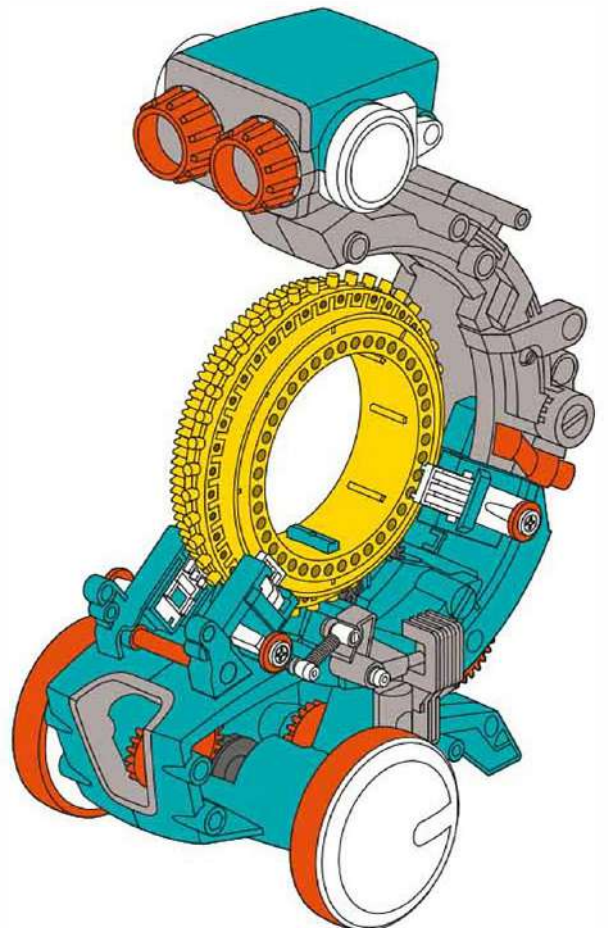

Obrót w prawo o 45 stopni

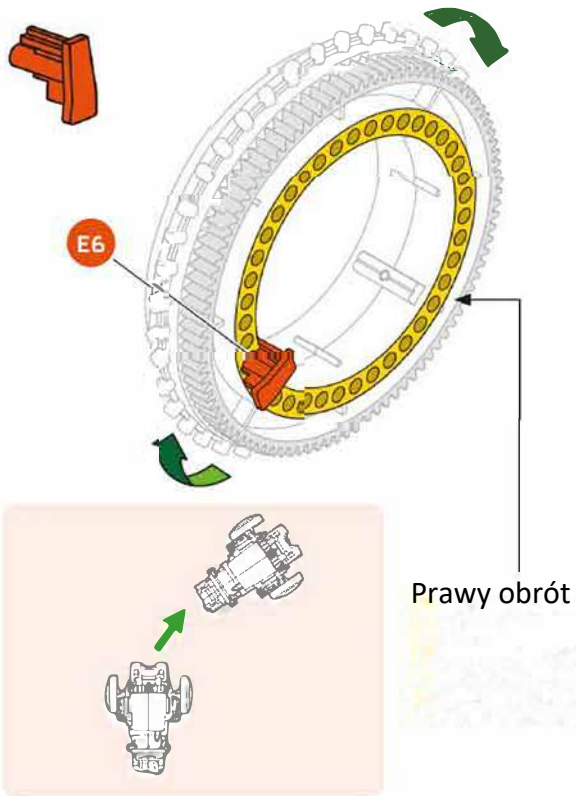

Obrót w prawo o 90 stopni

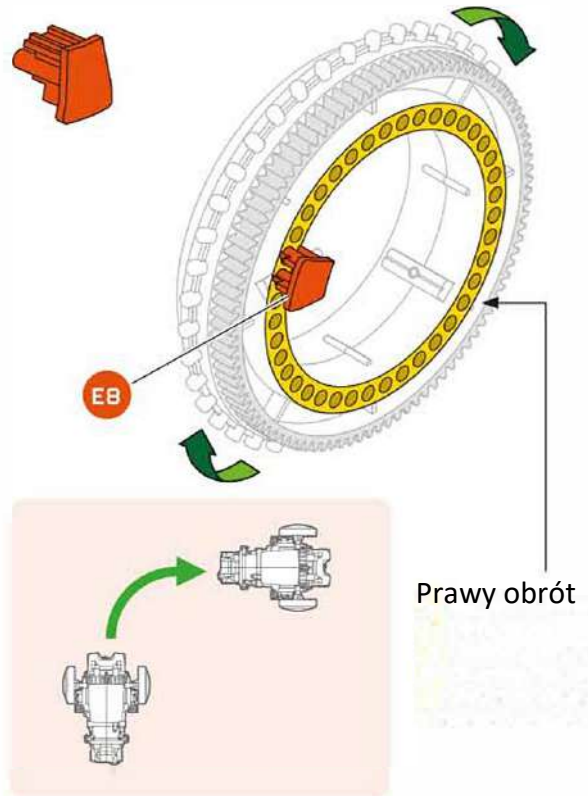

Obrót w lewo o 45 stopni

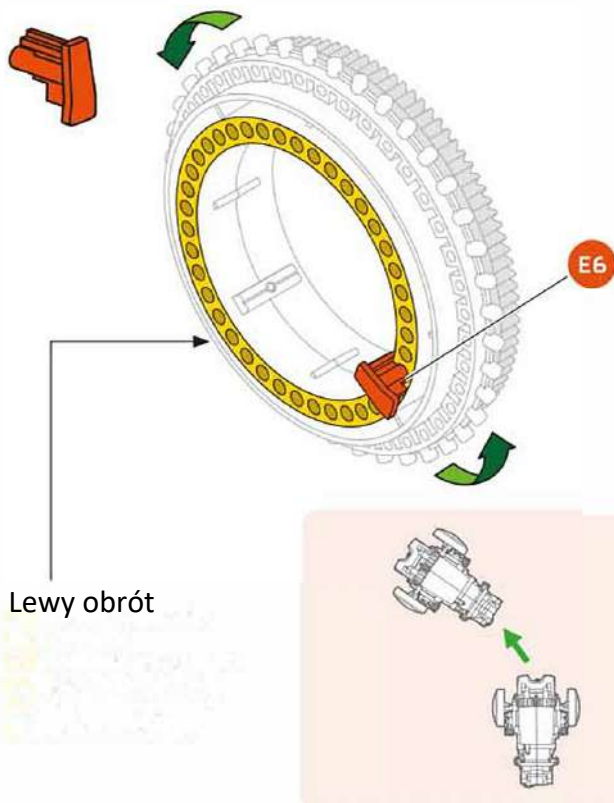

Obrót w lewo o 90 stopni

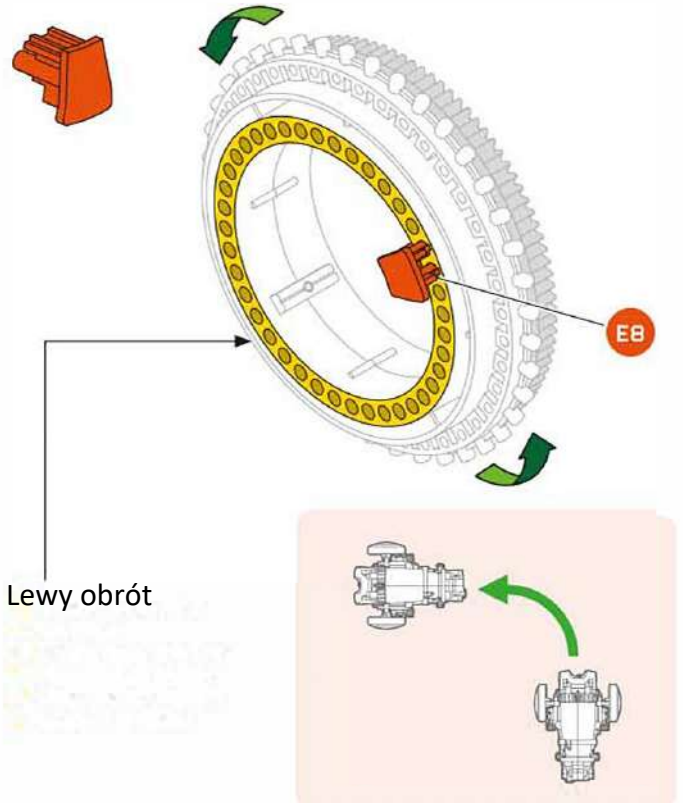

Obrót wstecz o 45 stopni w prawo

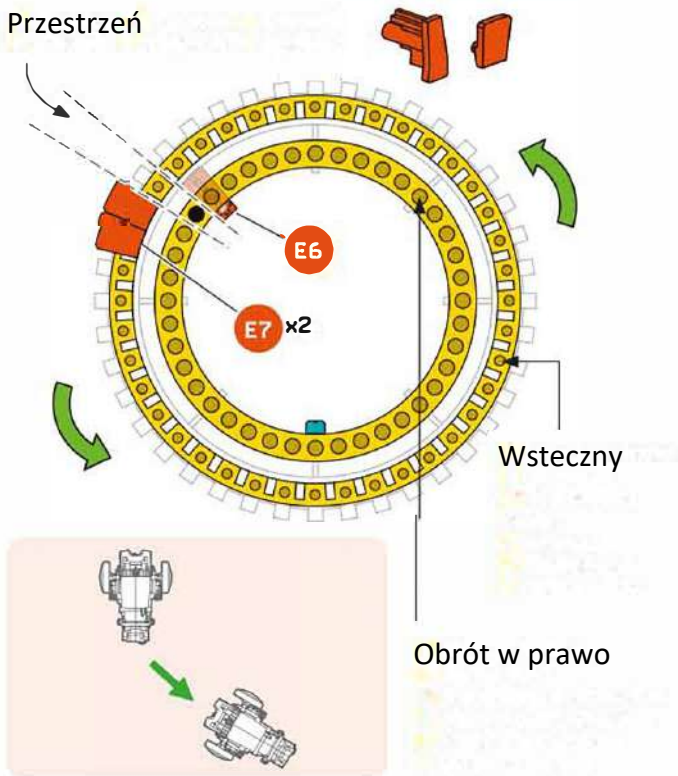

Obrót wstecz o 90 stopni w prawo

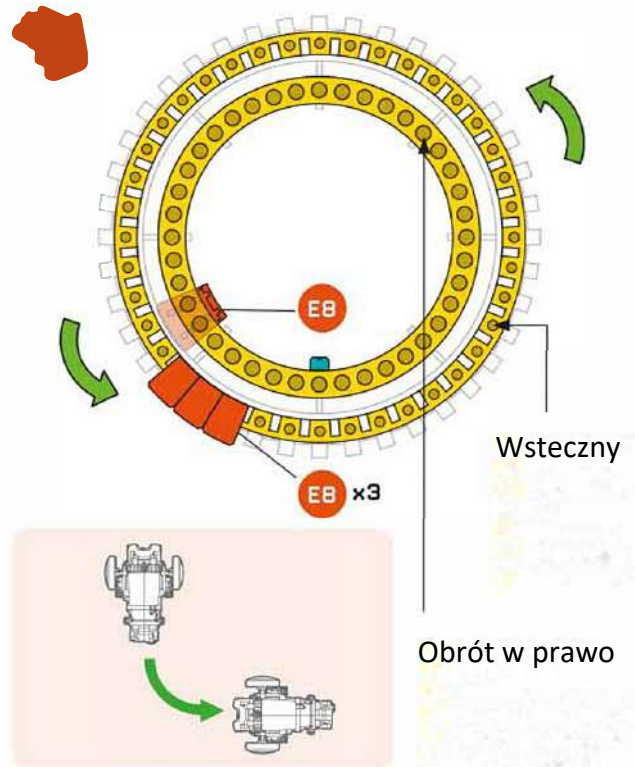

Obrót wstecz o 45 stopni w lewo

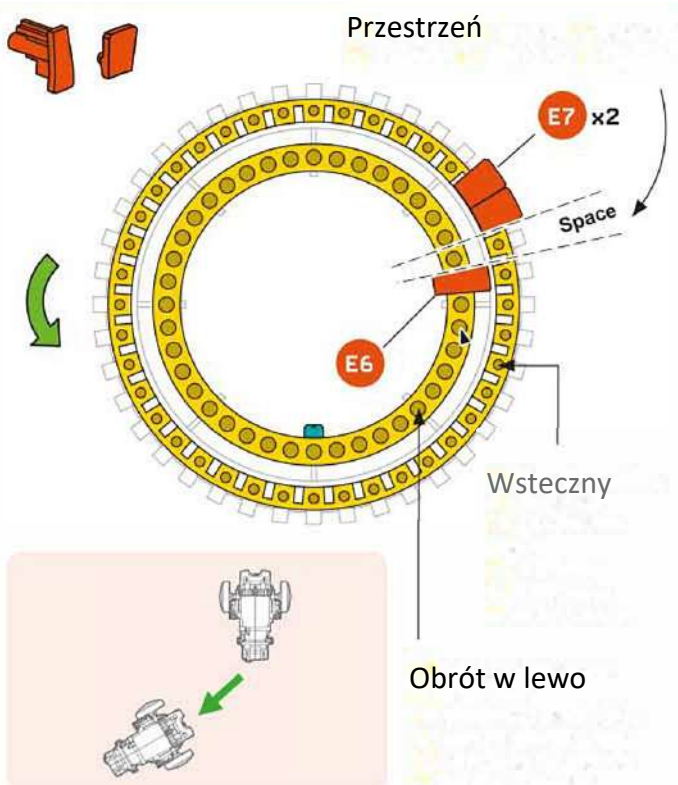

Obrót wstecz o 90 stopni w lewo

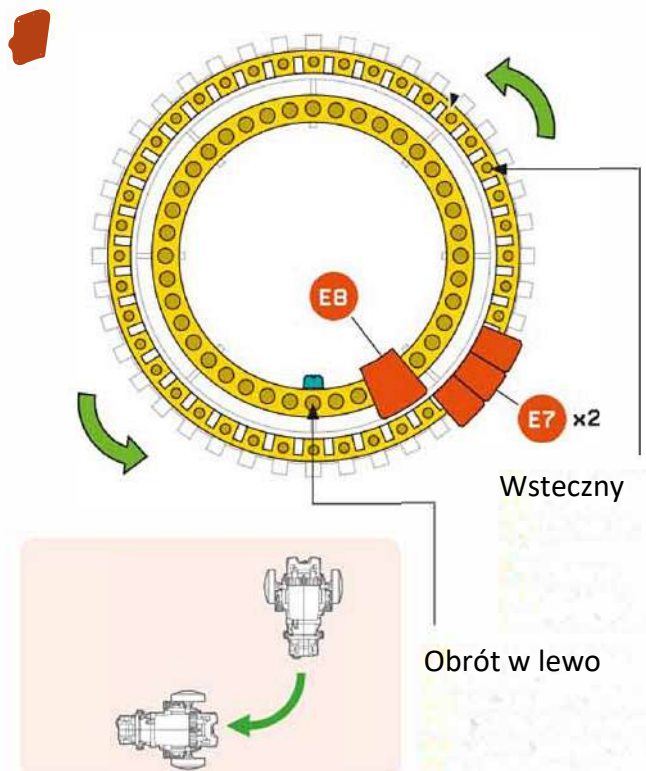

Wsteczny

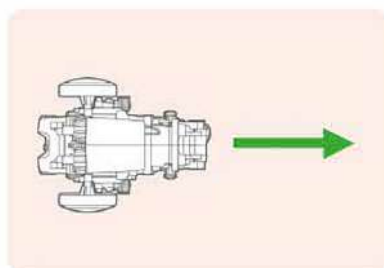
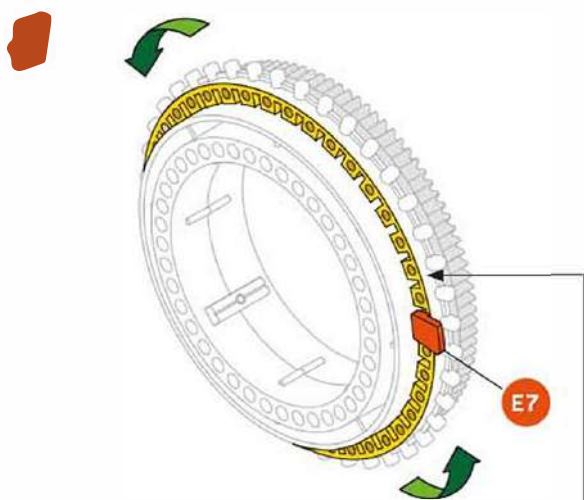

Wsteczny

Stop

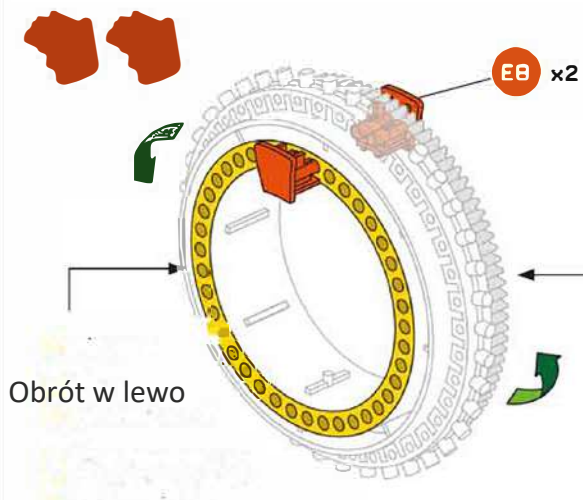

Obrót w lewo

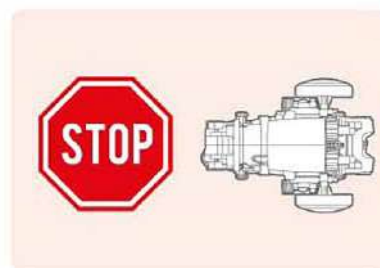

Obrót w prawo

Ruchy

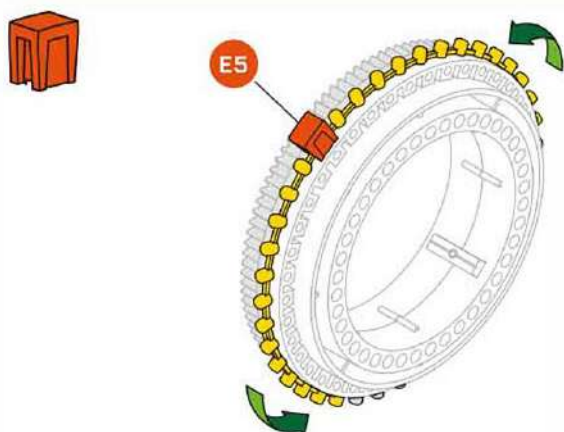

Lewa strona

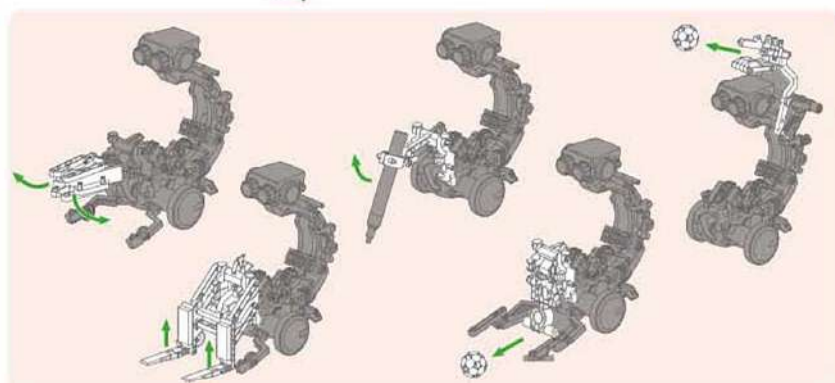

Montaż podnośnika



Lewa strona

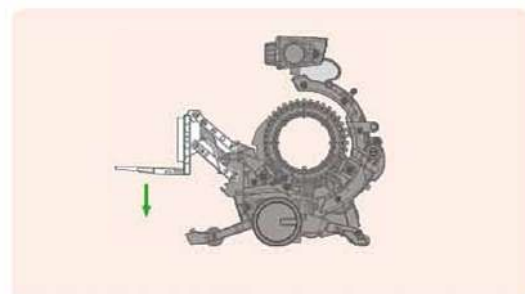



1

DESSINATEUR - DRAWING - ZEICHNER
TEKENAAR - DIBUJANTE - DISEGNATORE
RYSOWANIE

1

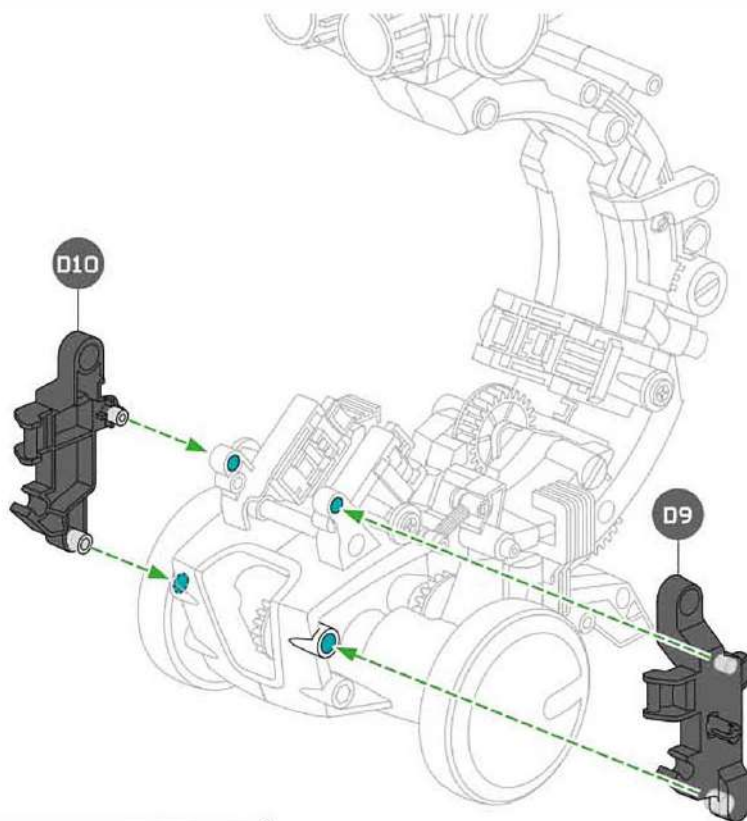

2

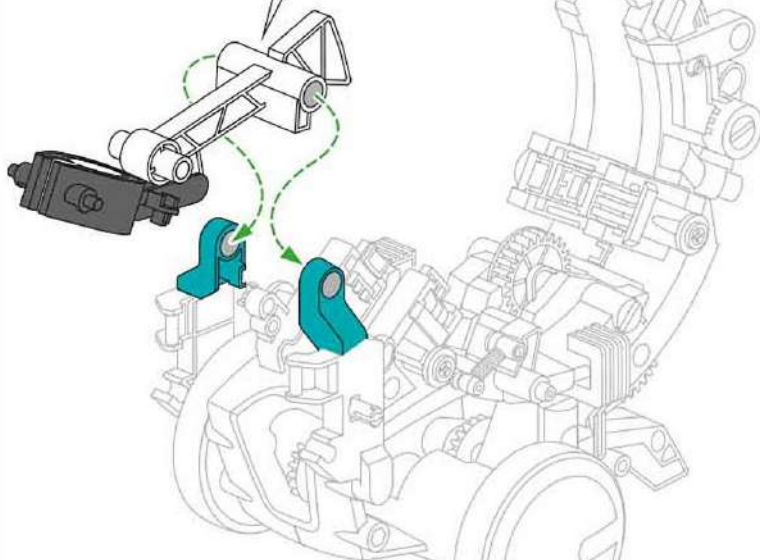
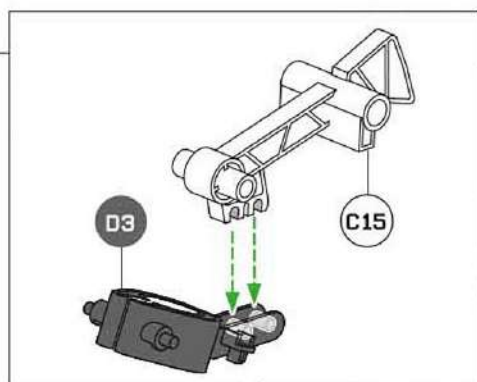

3

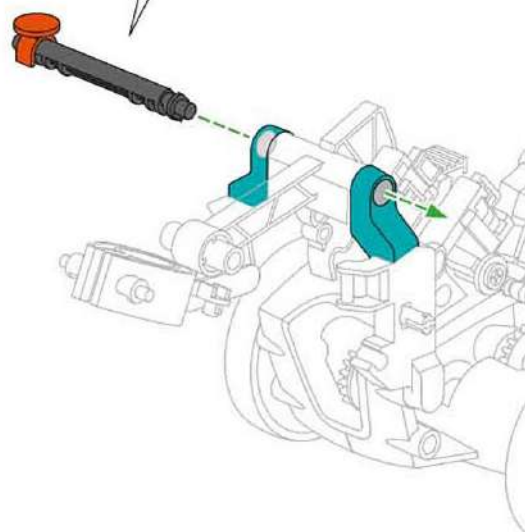
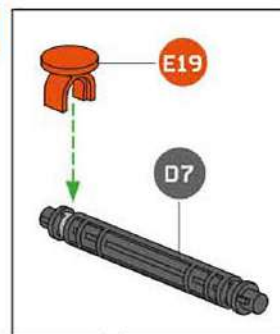



4

Pisak (nie ma w zestawie)

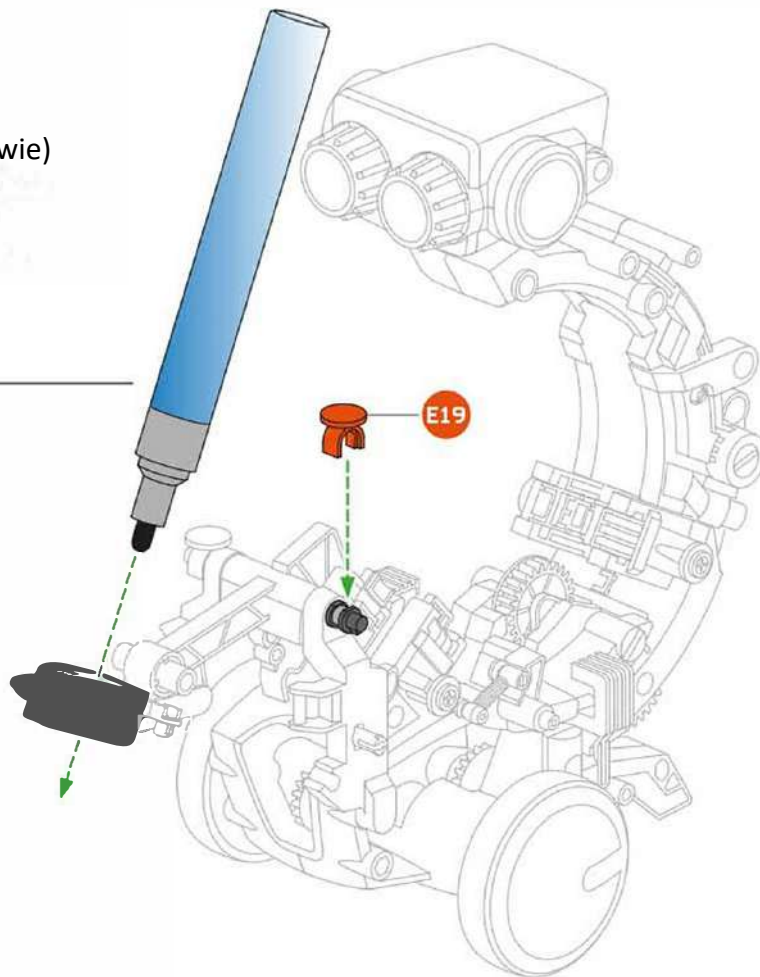

Scale 1:1

9.5cm

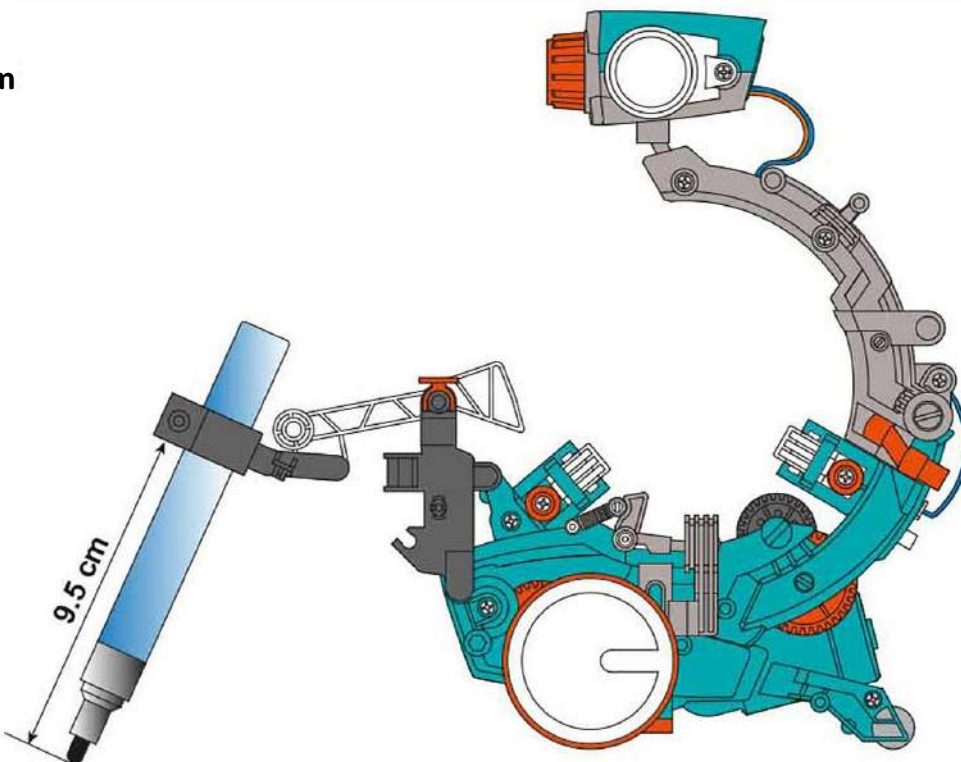

EXEMPLE - EXAMPLE: - BEISPIEL
VOORBEELD - EJEMPLO - ESEMPIO
PRZYKŁAD



Zwróć uwagę na kolejność montażu!

Będziesz potrzebować:



Lewa strona

Prawa strona

